

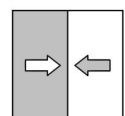

## Operating Manual

**DE27**

Digital differential pressure transmitter  
for gaseous media



## Masthead

**Manufacturer:****FISCHER Mess- und Regeltechnik GmbH**Bielefelderstr. 37a  
D-32107 Bad SalzuflenTelefon: +49 5222 974 0  
Telefax: +49 5222 7170eMail: [info@fischermesstechnik.de](mailto:info@fischermesstechnik.de)web: [www.fischermesstechnik.de](http://www.fischermesstechnik.de)**Technical editorial team:**

Documentation representative: S. Richter

Technical editor: R.Kleemann

All rights, also those to the translation, reserved. No part of these instructions may be reproduced or processed, duplicated or distributed using electronic systems or any other form (print, photocopy, microfilm or another process) without the written consent of the company FISCHER Mess- und Regeltechnik GmbH, Bad Salzuflen.

Reproduction for internal use is expressly allowed.

Brand names and procedures are used for information purposes only and do not take the respective patent situation into account. Great care was taken when compiling the texts and illustrations; nevertheless, errors cannot be ruled out. The company FISCHER Mess- und Regeltechnik GmbH will not accept any legal responsibility or liability for this.

Subject to technical amendments.



© FISCHER Mess- und Regeltechnik 2015

### Version history

Rev. ST4-A 06/15	Version 1	(first edition)
Rev. ST4-B 01/16	Version 2	List of special basic standards
Rev. ST4-C 03/17	Version 3	Casing modification
Rev. ST4-D 07/17	Version 4	Firmware change
Rev. ST4-E 11/17	Version 5	Correction of hose connection

# Table of contents

<b>1</b>	<b>Safety notes</b>	<b>4</b>
1.1	General	4
1.2	Personnel Qualification	4
1.3	Risks due to Non-Observance of Safety Instructions	4
1.4	Safety Instructions for the Operating Company and the Operator	4
1.5	Unauthorised Modification	4
1.6	Inadmissible Modes of Operation	5
1.7	Safe working practices for maintenance and installation work	5
1.8	Pictogram explanation	5
<b>2</b>	<b>Product and functional description</b>	<b>6</b>
2.1	Delivery scope	6
2.2	Equipment versions	6
2.3	Use as intended	6
2.4	Function diagram	6
2.5	Design and mode of operation	7
<b>3</b>	<b>Installation and assembly</b>	<b>8</b>
3.1	General	8
3.2	Process connection	8
3.3	Electrical connections	8
<b>4</b>	<b>Commissioning</b>	<b>10</b>
4.1	General	10
4.2	Measured Value Display	10
4.3	Configuration	10
<b>5</b>	<b>Maintenance</b>	<b>15</b>
5.1	Maintenance	15
5.2	Transport	15
5.3	Service	15
5.4	Accessories	15
5.5	Disposal	15
<b>6</b>	<b>Technical data</b>	<b>16</b>
6.1	General	16
6.2	Input variables	16
6.3	Output parameters	16
6.4	Measurement accuracy	16
6.5	Auxiliary energy	17
6.6	Application conditions	17
6.7	Display and operating interface	17
6.8	Construction design	18
<b>7</b>	<b>Order Codes</b>	<b>19</b>
<b>8</b>	<b>Attachments</b>	<b>21</b>

# 1 Safety notes

## 1.1 General



### **WARNING**

This operating manual contains instructions fundamental to the installation, operation and maintenance of the device that must be observed unconditionally. It must be read by the assembler, operator and the specialized personnel in charge of the instrument before it is installed and put into operation.

This operating manual is an integral part of the product and therefore needs to be kept close to the instrument in a place that is accessible at all times to the responsible personnel.

The following sections, in particular instructions about the assembly, commissioning and maintenance, contain important information, non-observance of which could pose a threat to humans, animals, the environment and property.

The instrument described in these operating instructions is designed and manufactured in line with the state of the art and good engineering practice.

## 1.2 Personnel Qualification

The instrument may only be installed and commissioned by specialized personnel familiar with the installation, commissioning and operation of this product.

Specialized personnel are persons who can assess the work they have been assigned and recognize potential dangers by virtue of their specialized training, their skills and experience and their knowledge of the pertinent standards.

## 1.3 Risks due to Non-Observance of Safety Instructions

Non-observance of these safety instructions, the intended use of the device or the limit values given in the technical specifications can be hazardous or cause harm to persons, the environment or the plant itself.

The supplier of the equipment will not be liable for damage claims if this should happen.

## 1.4 Safety Instructions for the Operating Company and the Operator

The safety instructions governing correct operation of the instrument must be observed. The operating company must make them available to the installation, maintenance, inspection and operating personnel.

Dangers arising from electrical components, energy discharged by the medium, escaping medium and incorrect installation of the device must be eliminated. See the information in the applicable national and international regulations.

Please observe the information about certification and approvals in the Technical Data section.

## 1.5 Unauthorised Modification

Modifications of or other technical alterations to the instrument by the customer are not permitted. This also applies to replacement parts. Only the manufacturer is authorised to make any modifications or changes.

## 1.6 Inadmissible Modes of Operation

The operational safety of this instrument can only be guaranteed if it is used as intended. The instrument model must be suitable for the medium used in the system. The limit values given in the technical data may not be exceeded.

The manufacturer is not liable for damage resulting from improper or incorrect use.

## 1.7 Safe working practices for maintenance and installation work

The safety instructions given in this operating manual, any nationally applicable regulations on accident prevention and any of the operating company's internal work, operating and safety guidelines must be observed.

The operating company is responsible for ensuring that all required maintenance, inspection and installation work is carried out by qualified specialized personnel.

## 1.8 Pictogram explanation



### **DANGER**

#### Type and source of danger

This indicates a **direct** dangerous situation that could lead to death or **serious injury** (highest danger level).

- a) Avoid danger by observing the valid safety regulations.



### **WARNING**

#### Type and source of danger

This indicates a **potentially** dangerous situation that could lead to death or **serious injury** (medium danger level).

- a) Avoid danger by observing the valid safety regulations.



### **CAUTION**

#### Type and source of danger

This indicates a **potentially** dangerous situation that could lead to slight or serious injury, damage or **environmental pollution** (low danger level).

- a) Avoid danger by observing the valid safety regulations.



### **NOTICE**

#### Note / advice

This indicates useful information of advice for efficient and smooth operation.

## 2 Product and functional description

### 2.1 Delivery scope

- DE27 configured
- Operating Manual

### 2.2 Equipment versions

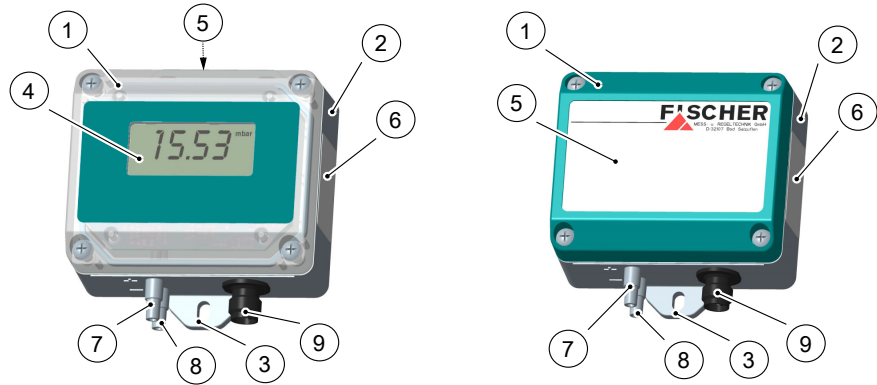

a) Model with measurement data display

b) Model without measurement data display

Illustration 1: Equipment versions

1	Casing lid	2	Lower part of casing
3	Fixing lug	4	LC display
5	Nameplate	6	Circuit diagram M12 plug
7	Process connection (+)	8	Process connection (-)
9	M12 plug		

### 2.3 Use as intended

The DE27 is a multi-functional differential pressure transmitter. It is suitable for measuring overpressure, under-pressure and differential pressure in dry and neutral gaseous media.

### 2.4 Function diagram

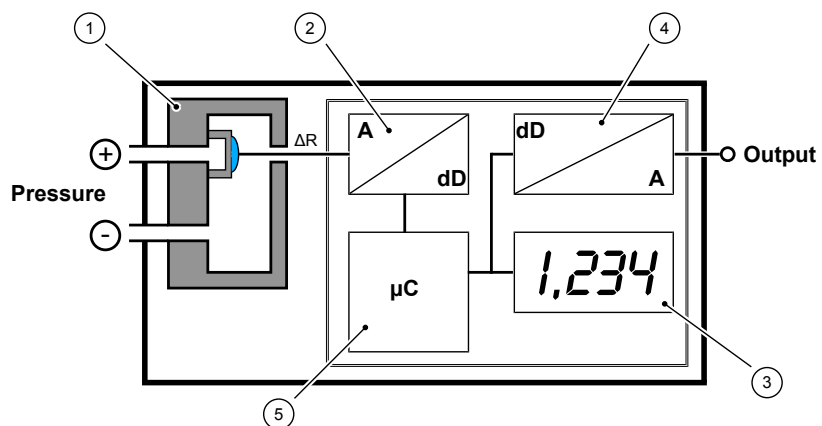

Illustration 2: Function diagram DE27

1	Sensor element	2	Signal converter
3	LC display	4	Analogue output
5	Micro-controller		

## 2.5 Design and mode of operation

The basis of this transmitter is a piezo-resistive sensor element. The pressures to be measured directly act on a silicon diaphragm equipped with piezo-resistive resistors. Changes in pressure generate proportional changes in resistance, which is evaluated by the device's electronics and transformed into signals on the optional display, and converted into an output signal.

The output signal, which is optionally available as a current or voltage signal <sup>(1)</sup> can be dampened, spread and inverted. Configuration is realised via a Transmitter PC Interface (EU03) that is available as an accessory.

---

<sup>(1)</sup> see order code

## 3 Installation and assembly

### 3.1 General

All supply lines are arranged so that there are no mechanical forces acting on the device.

The device is designed for installation onto flat assembly plates or walls. The device has moulded assembly lugs for screwing into position.

Ex-works, the device is set for vertical installation. Any installation position is possible.

### 3.2 Process connection

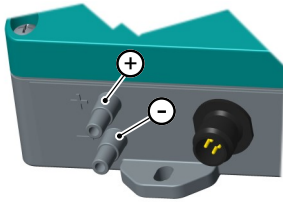

Illustration 3: Process connection

- By authorized and qualified specialized personnel only.
- The pipes need to be depressurized when the instrument is being connected.
- Appropriate steps must be taken to protect the device from pressure surges.
- Check that the device is suitable for the medium being measured.
- Maximum pressures must be observed (cf. Tech. data)



#### **⚠ CAUTION**

**Do not blow into the pressure connections.**

This may damage the sensor.

The pressure lines must be kept as short as possible and installed without any tight bends to avoid delays.

The process connections are marked with (+) and (-) symbols on the device. The pressure lines must be mounted according to these symbols.

#### 1. Differential pressure measurement

- ⊕ Higher pressure
- ⊖ lower pressure

#### 2. Pressure measurement

- ⊕ Pressure
- ⊖ open

#### 3. Under-pressure measurement

- ⊕ open
- ⊖ Under-pressure

### 3.3 Electrical connections

- By authorized and qualified specialized personnel only.
- When connecting the unit, the national and international electro-technical regulations must be observed.
- Disconnect the system from the mains, before electrically connecting the device.
- Install the consumer-adapted fuses.
- Do not connect the connector if strained.



### 2-wire circuit 4...20 mA output

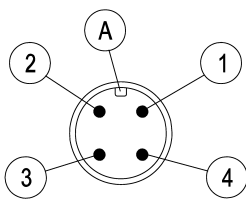
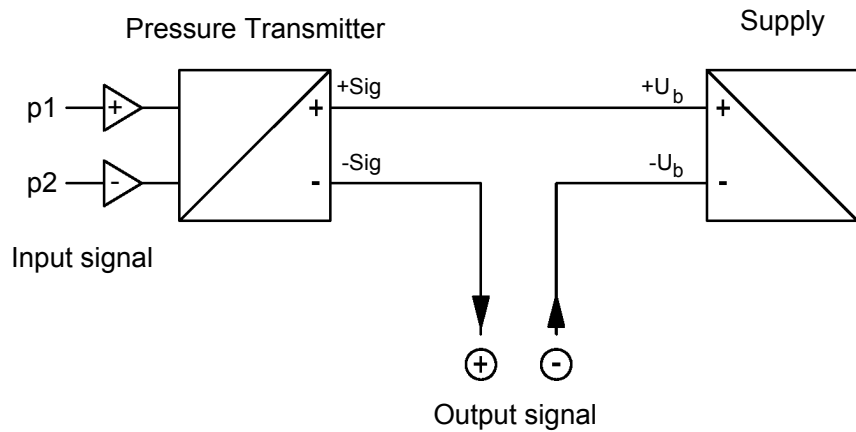

Illustration 4: M12 plug 4-pin

Pin	Signal name		Cable colour
1	Supply / output signal	+U <sub>b</sub> /+Sig	brown
2	n.c.		white
3	Supply / output signal	-U <sub>b</sub> /-Sig	blue
4	n.c.		black
A	Coding		

### 3-wire circuit 0...10 V output

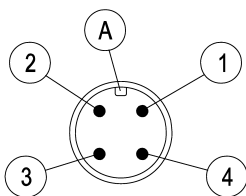
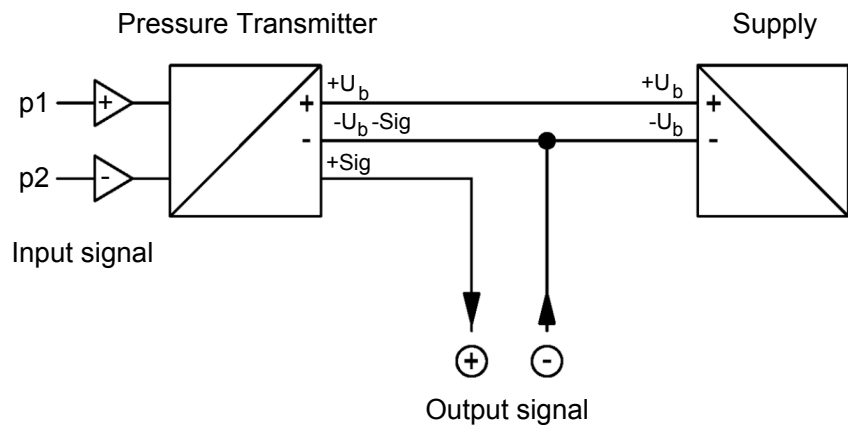

Illustration 5: M12 plug 4-pin

Pin	Signal name		Cable colour
1	Supply	+U <sub>b</sub>	brown
2	n.c.		white
3	Supply / output signal	-U <sub>b</sub> /-Sig	blue
4	Output signal	+Sig	black
A	Coding		

## 4 Commissioning

### 4.1 General

All electrical supply, operating and measuring lines, and the pressure connections must have been correctly installed before commissioning. All supply lines are arranged so that there are no mechanical forces acting on the device.

Check that the pressure connections do not leak before commissioning.

### 4.2 Measured Value Display

The measured value display shows the current differential pressure in normal mode. The selected measuring unit is illuminated on the right of the display.

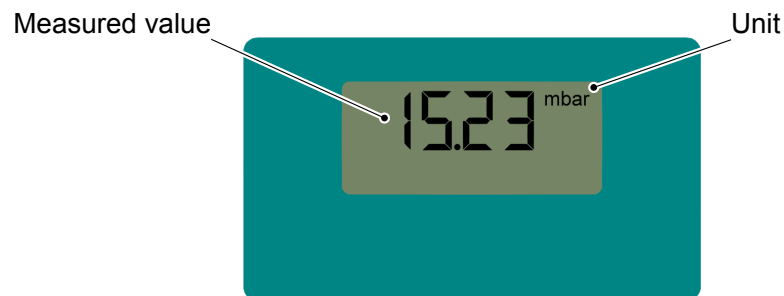

Illustration 6: Measured Value Display

### 4.3 Configuration

The device is configured in the factory before delivery. However, it is possible to configure the DE27 via a PC. You will need a Transmitter PC Interface (EU03) and the FernPara software from V2.19.

For more information about installation and operation, please see the operating instructions of the software<sup>(2)</sup>. For more information about the order see accessories [► 20].

Connect the unit as follows to configure the DE27.

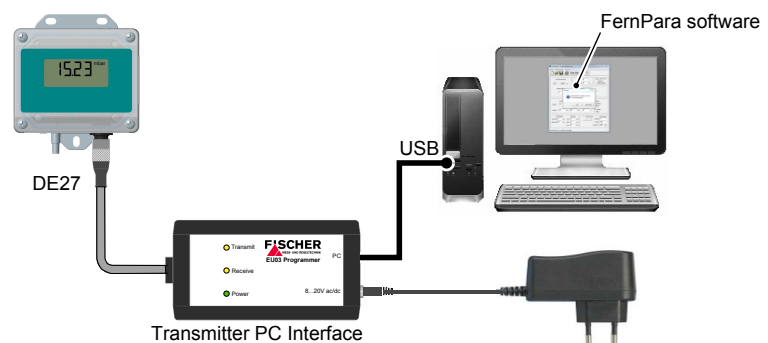

Illustration 7: Parameter connection diagram

Once a connection to the transmitter has been made, start the FernPara software and export the transmitter data.

<sup>(2)</sup> see Online help

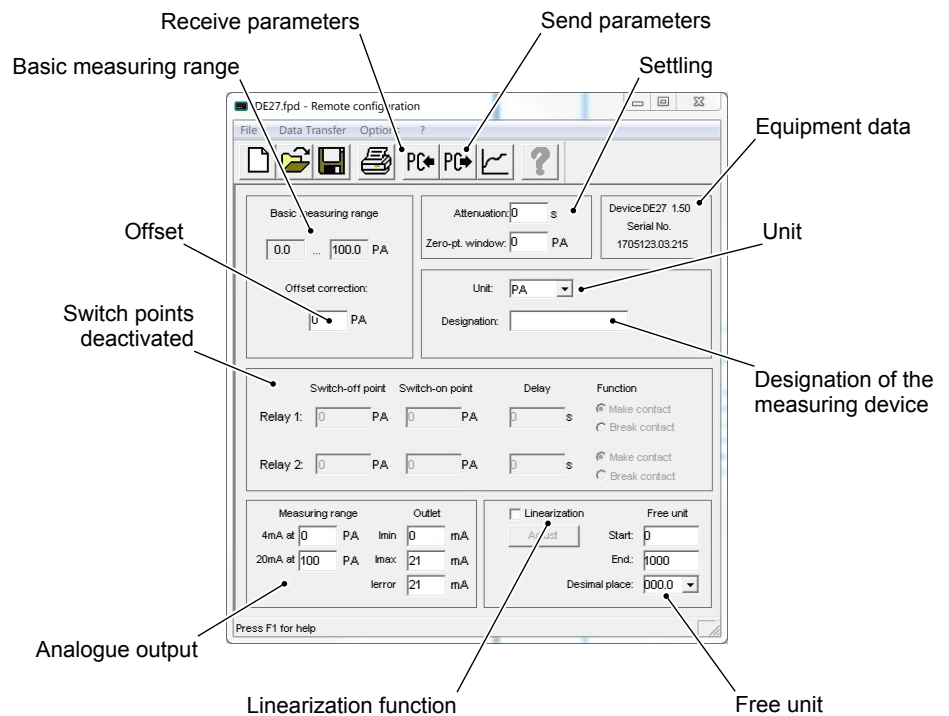

Illustration 8: FernPara master screen

#### 4.3.1 Designation

You can enter a name for the measuring point in this field.

#### 4.3.2 Basic measuring range

At this point, the basic measuring range of the DE27 is shown as stated on the type plate. The basic measuring range is stated when the device is ordered in compliance with the order code, and cannot be changed.

#### 4.3.3 Offset

The transmitter is dependent on the position to a certain extent, especially for smaller measuring ranges. For compensation purposes, you can use the parameter **Offset** to enter a correction. The offset is stated in pressure units and comprises a value range of  $\pm 1/3$  of the basic measuring range.

#### 4.3.4 Settling

You can use the parameter **Damping** to activate the filter function and thereby settle the measured values. Set the jump response time here (0.0 ... 100.0s) to adapt the transmitter to your measuring task. You can use the parameter **Zero-point window** to stabilise the display around zero. The information is stated in pressure units and comprises a value range of  $\pm 1/3$  of the basic measuring range. The zero point window defines a range around zero in which the measured value is permanently set to zero. Outside the range the measured value is approached as follows:

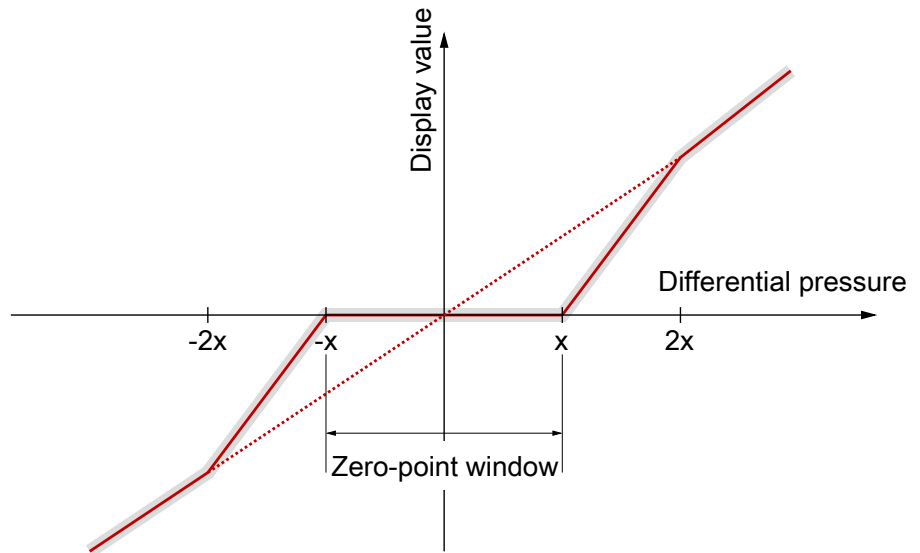

Illustration 9: Zero-point window

### 4.3.5 Unit

You can select the required unit from a dropdown list for the parameter **Unit**.

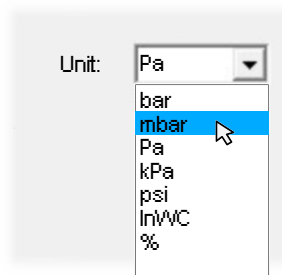

Illustration 10: Dropdown list unit

### 4.3.6 Analogue output

You can spread the analogue output within the basic measuring range to maximum 1:4. Initially, the values of the basic measuring range are shown in the input fields for the measuring range. The start and end of the measuring range parameters can be any values within the basic measuring range. However the difference of the two values must be at least 25% of the basic measuring range.

#### Example current output

- Basic measuring range 0...100 Pa
- Output 4...20 mA
- Set measurement range = 10 ... 35 Pa (spread 1:4)

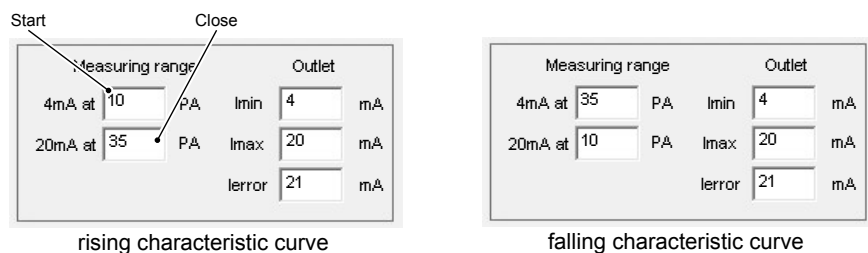

Illustration 11: Characteristic curve

You can limit the control range for a current output without changing the scale via the input fields Imin and Imax parameters for the output. **Imin** = 4 mA may not be undercut.

You define an output signal that is issued in case of a transmitter error with **Ierror**.

To deactivate the limit values, set **Imin** and **Imax** to 0. If you set **Ierror** to 0, no error signal will be generated.

**Example voltage output:**

- Basic measuring range 0...100 Pa
- Output 0...10V
- Set measurement range = 10 ... 35 Pa (spread 1:4)

Measuring range		Outlet	
0V at	10 PA	Umin	0 R
10V at	35 PA	Umax	10 R
		Uerror	11 R

rising characteristic curve

Measuring range		Outlet	
0V at	35 PA	Umin	0 R
10V at	10 PA	Umax	10 R
		Uerror	11 R

falling characteristic curve

Illustration 12: Characteristic curve voltage output

You can limit the control range for a voltage output without changing the scale via the input fields Umax and/or Uerror parameters for the output.

You define an output signal that is issued in case of a transmitter error with **Uerror**.

To deactivate the limit values, set **Umin** and **Umax** to 0. If you set **Uerror** to 0, no error signal will be generated.

**Linearization function**

This function allows free adjustment of the input variable to the display and output via a table with up to 30 support points.

<input checked="" type="checkbox"/> Linearization	Free unit
<input type="button" value="Adjust"/>	Start: 0
	End: 2565
	Commast: 000.0

MB start (free unit) → Start: 0  
 MB end (free unit) → End: 2565  
 Decimal places (free unit) → Commast: 000.0

Illustration 13: Linearization

As soon as the linearization function is activated, the display automatically changes to free unit. This display shows a numeric value with the set decimal places without a unit.

if the 'Adapt' button is pressed, the window with the transfer function opens.

## An Example

- Basic measuring range 0...100 Pa
- Output 4...20 mA
- Set measurement range = 0 ... 80 Pa (spread 1:1.25)
- Measuring range free unit 0...2565
- Decimal place 000.0
- Support points 30 (Default value)

The set measuring range is divided into 30 support pairs, in which each measured value is assigned to a calculated display value of the free unit. This then results in a table comprising 30 value pairs for the transfer function. The characteristic line between two support points is interpolated in a linear fashion.

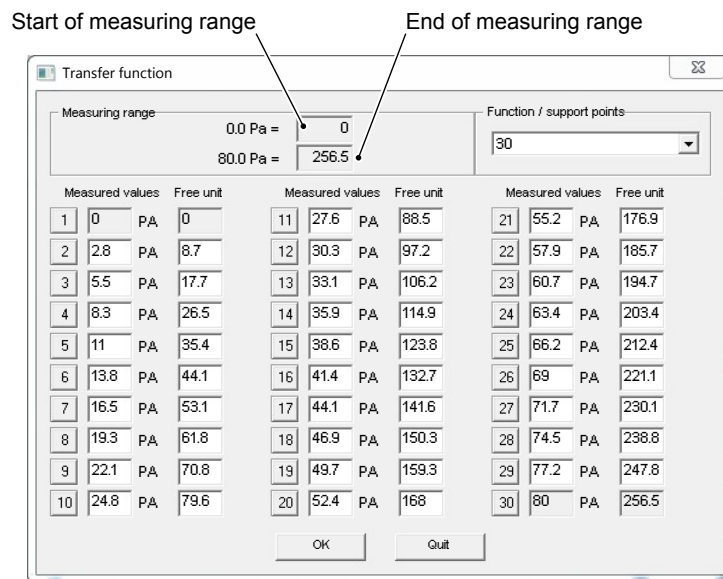

Illustration 14: Transfer function

You can now 'shift' individual support points and in this way create a customer-specific characteristic line that is ideally adapted to the circumstances of your application. The shift of a support point impacts on the display value and consequently on the analogue output. The value pairs for the measuring range start and measuring range end are permanently defined, and cannot be changed at this point.

You can reduce the number of support points by means of the dropdown list 'Function / support points', however a support point table must contain at least 3 value pairs.

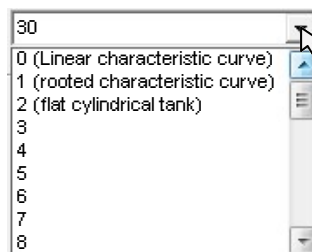

Illustration 15: Dropdown list functions / support points

The value 0 will return you to a linear characteristic curve (starting status). The linearization function is automatically deactivated and the set unit is shown on the display.

## 5 Maintenance

### 5.1 Maintenance

The instrument is maintenance-free. We recommend the following regular inspection to guarantee reliable operation and a long service life:

- Check the function in combination with downstream components.
- Check the leak-tightness of the pressure connection lines.
- Check the electrical connections.

The exact test cycles need to be adapted to the operating and environmental conditions. In combination with other devices, the operating instructions for the other devices also need to be observed.

### 5.2 Transport

The measuring device must be protected against impacts. It should be transported in the original packaging or a suitable transport container.

### 5.3 Service

All defective or faulty devices should be sent directly to our repair department. Please coordinate all shipments with our sales department.



#### **WARNING**

##### **Process media residues**

Process media residues in and on dismantled devices can be a hazard to people, animals and the environment. Take adequate preventive measures. If required, the devices must be cleaned thoroughly.

Return the device in the original packaging or a suitable transport container.

### 5.4 Accessories

- M12 connection lines in various lengths
- EU03 transmitter PC interface for remote configuration
- Connection set for intake and outlet channels

For the order numbers, please see the order code [▶ 19].

### 5.5 Disposal



#### **WARNING**

Incorrect disposal may pose a risk to the environment.

Please help to protect the environment by always disposing of the work pieces and packaging materials in compliance with the valid national waste and recycling guidelines or reuse them.

## 6 Technical data

### 6.1 General

Please also observe the order code here.

### 6.2 Input variables

In addition to the listed units the following units are also available: bar, kPa, psi, InWC and %.

Basic measuring range		Stat. operating pressure max.		Bursting pressure	
mbar	Pa	mbar	kPa	mbar	kPa
0 ... 4	0 ... 400	50	5	150	15
0 ... 6	0 ... 600	50	5	150	15
0 ... 10	0 ... 1000	100	10	300	30
0 ... 16	0 ... 1600	100	10	300	30
0 ... 25	0 ... 2500 <sup>*)</sup>	250	25	750	75
0 ... 40	0 ... 4000 <sup>*)</sup>	250	25	750	75
0 ... 60	0 ... 6000 <sup>*)</sup>	500	50	750	75
0 ... 100	---	500	50	750	75
-2.5 ... +2.5	-250 ... +250	50	5	150	15
-4 ... +4	-400 ... +400	50	5	150	15
-6 ... +6	-600 ... +600	50	5	150	15
-10 ... +10	-1000 ... +1000	100	10	300	30
-16 ... +16	-1600 ... +1600	100	10	300	30
-25 ... +25	-2500 ... +2500 <sup>*)</sup>	250	25	750	75
-40 ... +40	-4000 ... +4000 <sup>*)</sup>	250	25	750	75
-60 ... +60	-6000 ... +6000 <sup>*)</sup>	500	500	750	75

<sup>\*)</sup> Only available for 4-digit display resolution (-9999 ... +9999). The last digit in this case can be slightly unsettled.

### 6.3 Output parameters

Output signal	4 ... 20 mA	0 ... 10 V
Connection type	2-Wire	3-Wire
Load	$R_L \leq (U_b - 6V)/0.02 \text{ A}$	$U_b = 12 \dots 15V \quad R_L \geq 15 \text{ k}\Omega$ $U_b > 15 \text{ V} \quad R_L \geq 12 \text{ k}\Omega$

### 6.4 Measurement accuracy

	Measuring range	0...	4	6	10	16	25	40	60	100
Characteristic curve deviation <sup>o)*)</sup>	Max. %FS					2.5 (1.0)				
	Type %FS					1.5 (0.5)				
TK span <sup>x)</sup>	Max. %FS		1.0	1.0	0.3	0.3	0.3	0.3	0.3	0.3
	Type %FS		0.3	0.3	0.3	0.3	0.3	0.3	0.3	0.3
Tk zero-point <sup>x)</sup>	Max. %FS / 10K		1.0	1.0	0.4	0.4	0.4	0.4	0.4	0.4
	Type %FS / 10K		0.2	0.2	0.2	0.2	0.2	0.2	0.2	0.2



	Measuring range	$\pm 2.5$	$\pm 4$	$\pm 6$	$\pm 10$	$\pm 16$	$\pm 25$	$\pm 40$	$\pm 60$
<b>Characteristic curve deviation <sup>o)</sup></b>	Max. %FS					2.5 (1.0)			
	Type %FS					1.5 (0.5)			
<b>TK span <sup>x)</sup></b>	Max. %FS / 10K	1.0	0.5	0.3	0.3	0.3	0.3	0.3	0.3
	Type %FS / 10K	0.3	0.3	0.3	0.3	0.3	0.3	0.3	0.3
<b>Tk zero-point <sup>x)</sup></b>	Max. %FS / 10K	1.0	0.5	0.4	0.4	0.4	0.4	0.4	0.4
	Type %FS / 10K	0.2	0.2	0.2	0.2	0.2	0.2	0.2	0.2

<sup>o)</sup> Characteristic curve deviation (non-linearity and hysteresis) at 25°C and rated voltage basic measuring range with linear characteristic curve, not spread

A smaller deviation can be realised in certain measuring ranges (values in brackets). Please contact our sales department in this case.

<sup>x)</sup> In relation to the basic measuring range with a linear, not spread, characteristic curve.

## 6.5 Auxiliary energy

Characteristic value	2-Wire	3-Wire
Rated Voltage	24 V DC	24 V AC/DC
Admissible operating voltage $U_b$	6 ... 32 V DC	12 ... 32 V AC/DC
Power consumption	$\leq 22$ mA	$\leq 15$ mA

## 6.6 Application conditions

Permissible ambient temperature	-10 ... +70 °C
Admissible medium temperature	-10 ... +70 °C
Admissible storage temperature	-20 ... +70 °C
Enclosure protection class	IP65 acc. to DIN EN 60529
EMC	EN 61326-1:2013 EN 61326-2-3:2013
RoHS	EN 50581:2012

## 6.7 Display and operating interface

### 6.7.1 Measured Value Display

3½ digit LCD	-1999 ... +1999
4 digit LCD	-9999 ... +9999



## NOTICE

### 4 digit LCD

In 4-digit display resolutions, the display resolution may be larger than the measuring resolution (approx. 3500 digits). This may cause an unsettled display.

### 6.7.2 Operating interface

The device does not have a keyboard; this means that the customer can only configure it using the Transmitter PC Interface EU03 (accessory).

Parameter	Value range
Attenuation	0.0 ... 100.0 s (jump response time 10 / 90 %)
Zero-point window	$\pm\frac{1}{3}$ basic measuring range <sup>(0)</sup>
Unit	bar, mbar, Pa, kPa, psi, InWC, % <sup>(1)</sup>
Offset	$\pm\frac{1}{3}$ basic measuring range
Measuring range start/end	Within the basic measuring range <sup>(2)</sup>
Measurement range characteristic curve	Linear, max. turn down 4:1, inverted, rooted, table
Free unit	-9999 ... +9999
Measuring range start/end	

<sup>(0)</sup> This value defines the range around the zero-point in which the measured value is set to zero, e.g. for creep flow suppression.

<sup>(1)</sup> The unit '%' refers to the measuring range defined by the start of the measuring range (0%) and the end of the measuring range (100%).

<sup>(2)</sup> This only impacts on the output signal. A falling characteristic curve is possible, if the start of the measuring range > end of the measuring range.

### 6.8 Construction design

#### Process connection

Plug nipple for 6/4 mm or 8/6 mm hose

#### Materials

Housing	with display	without display
Lower part of casing	Polyamide PA 6.6	Polyamide PA 6.6
Casing lid	Polycarbonate PC	Polyamide PA 6.6

**Media-contacting material** Silicon, PVC, aluminium, brass

#### Assembly

Wall mounting

#### Dimensional drawing

All dimensions in mm unless otherwise stated

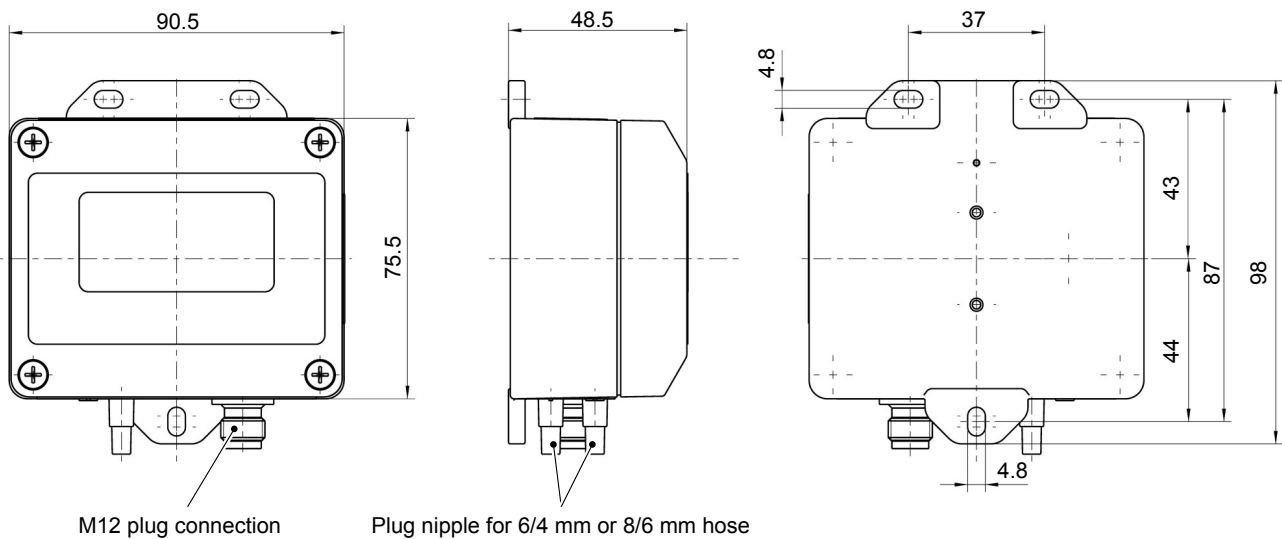

Illustration 16: Dimensional drawing

## 7 Order Codes

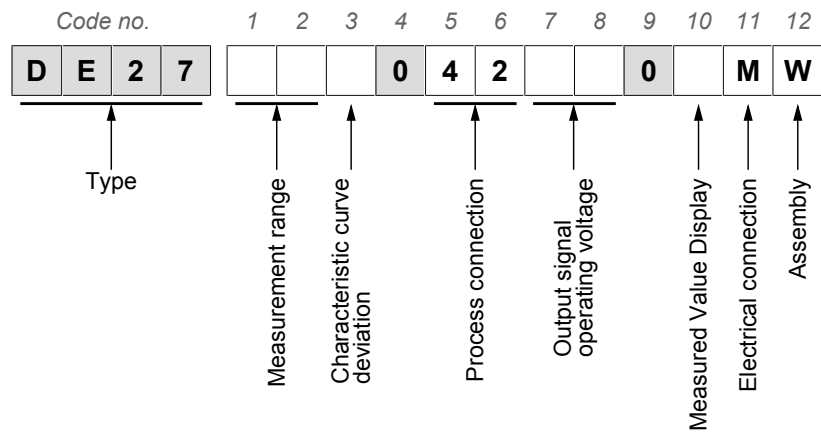

Illustration 17: Order Codes

### Measurement range

[1.2]	Measurement range	Static operating pressure
52	0 ... 4 mbar	50 mbar
53	0 ... 6 mbar	50 mbar
54	0 ... 10 mbar	100 mbar
55	0 ... 16 mbar	100 mbar
56	0 ... 25 mbar	250 mbar
57	0 ... 40 mbar	250 mbar
58	0 ... 60 mbar	500 mbar
59	0 ... 100 mbar	500 mbar
A6	-2.5 ... +2.5 mbar	50 mbar
A7	-4 ... +4 mbar	50 mbar
A8	-6 ... +6 mbar	50 mbar
A9	-10 ... +10 mbar	100 mbar
B1	-16 ... +16 mbar	100 mbar
B2	-25 ... +25 mbar	250 mbar
C5	-40 ... +40 mbar	250 mbar
B3	-60 ... +60 mbar	500 mbar
D7	0 ... 400 Pa	5 kPa
D8	0 ... 600 Pa	5 kPa
D9	0 ... 1000 Pa	10 kPa
E1	0 ... 1600 Pa	10 kPa
E2	0 ... 2500 Pa	25 kPa
E3	0 ... 4000 Pa	25 kPa
E4	0 ... 6000 Pa	50 kPa
N3	0 ... 2.5 kPa	25 kPa
N4	0 ... 4.0 kPa	25 kPa

### Characteristic curve deviation (relative pressure)

[3]	
K	Characteristic curve deviation 2.5%
M	Characteristic curve deviation 1.0% <sup>(0)</sup>

<sup>(0)</sup> A characteristic curve deviation of 1% cannot be realised for all measuring ranges. Please contact our sales department in this case.

<b>Process connection</b>	<b>[5.6]</b>		
	<b>42</b>	Plug nipple for 6/4 mm or 8/6 mm hose	
<b>Output signal operating voltage</b>	<b>[7.8] Outlet</b>		<b>Operating voltage</b>
	<b>BP</b>	4 ... 20 mA DC    2-Wire	24v DC
	<b>CK</b>	0 ... 10 V DC    3-Wire	24 V AC/DC
<b>Measured value display</b>	<b>[10]</b>		
	<b>0</b>	No measured value display	
	<b>1</b>	3½-digit measured value display	
	<b>A</b>	4-digit measured value display	
<b>Electrical connection</b>	<b>[11]</b>		
	<b>M</b>	M12 plug connection	
<b>Assembly</b>	<b>[12]</b>		
	<b>W</b>	Wall mounting	

### 7.1 Accessories

Order no.	length	No. of Poles	Designation	Usage
<b>06401993</b>	2m	4-pin	Connection cable with M12 connector	For supply and output signal
<b>06401994</b>	5m			
<b>06401563</b>	7m			
<b>06401572</b>	10m			
<b>06401566</b>	15m			

#### Transmitter PC Interface

Order no.	
<b>EU03 F300</b>	Transmitter PC Interface incl. PC software for remote configuration of 3-wire transmitters
<b>EU03 F200</b>	Transmitter PC Interface incl. PC software for remote configuration of 2-wire transmitters

#### Connection set

Order no.	Designation	hose	length
04005129	Plastic connection set	2 x 6/4 mm	1m
04005148	Plastic connection set	2 x 6/4 mm	2.5 m
04005163	Plastic connection set	2 x 6/4 mm	5m
04005216	Plastic connection set	2 x 6/4 mm	10m
04005217	Plastic connection set	2 x 8/6 mm	1m
04005218	Plastic connection set	2 x 8/6 mm	5m

## 8 Attachments

### 8.1 EC Declaration of Conformity



#### EU Declaration of Conformity

(Translation)

For the product described as follows

**Product designation**      **Digital Differential Pressure Transmitter**

**Type designation**         **DE27**

it is hereby declared that it corresponds with the basic requirements specified in the following designated directives:

2014/30/EU                      EMC Directive  
2011/65/EU                      RoHS Directive

The products were tested in compliance with the following standards.

#### **Electromagnetic compatibility (EMC)**

EN 61326-1:2013                *Electrical equipment for measurement, control and laboratory use - EMC requirements - Part 1: General requirements*

EN 61326-2-3:2013              *Electrical equipment for measurement, control and laboratory use - EMC requirements - Part 2-3: Particular requirements - Test configuration, operational conditions and performance criteria for transducers with integrated or remote signal conditioning*

#### **RoHS**

EN 50581:2012                 *Technical documentation for the assessment of electrical and electronic products with respect to the restriction of hazardous substances*

Also they were subjected to the conformity assessment procedure „**Internal production control**“.

The object of the declaration described above is in conformity with Directive 2011/65/EU of the European Parliament and of the Council of 8 June 2011 on the restriction of the use of certain hazardous substances in electrical and electronic equipment.

Sole responsibility for the issue of this declaration of conformity in relation to fulfilment of the fundamental requirements and the production of the technical documents is with the manufacturer.

**Manufacturer**                 **FISCHER Mess- und Regeltechnik GmbH**  
Bielefelder Str. 37a  
32107 Bad Salzuflen, Germany  
Tel. +49 5222 974 0

**Documentation representative**      Mr. Stefan Richter  
Dipl. Ing.  
General Manager R & D

**The devices bear the following marking:**      **CE**

Bad Salzuflen,  
2017-03-16

S. Richter  
General Manager R & D

\*09010241\* CE\_EN\_DE27 Rev.B 03/17



Seite 1 von 1

Illustration 18: CE\_EN\_DE27





