

User Manual

DS11

Differential pressure switch



Contents

- 1 Safety guidelines
- 2 Application purpose
- 3 Product and functional description
- 4 Installation and assembly
- 5 Commissioning
- 6 Maintenance and Repeat Tests
- 7 Transport
- 8 Service
- 9 Accessories
- 10 Waste Disposal
- 11 Technical data
- 12 Dimensional drawings
- 13 Order Codes
- 14 Manufacturer's Declarations and Certificates

1 Safety guidelines

1.1 General



This operating manual contains instructions fundamental to the installation, operation and maintenance of the device that must be observed unconditionally. It must be read by the fitter, the operator and the responsible technical personnel before installation and commissioning of the device.

This operating manual is an integral part of the product and therefore needs to be kept close to the instrument in a place that is accessible at all times to the responsible personnel.

The following sections, in particular instructions about the assembly, commissioning and maintenance, contain important information, non-observance of which could pose a threat to humans, animals, the environment and property.

1.2 Personnel Qualification

The device may only be installed and commissioned by specialized personnel familiar with the installation, commissioning and operation of this product.

Specialized personnel are persons who can assess the work they have been assigned and recognize potential dangers by virtue of their specialized training, their skills and experience and their knowledge of the pertinent standards.



1.3 Risks due to Non-Observance of Safety Instructions

Non-observance of these safety instructions, the intended use of the device or the limit values given in the technical specifications can be hazardous or cause harm to persons, the environment or the plant itself.

The supplier of the equipment will not be liable for damage claims if this should happen.

1.4 Safety Instructions for the Operating Company and the Operator

The safety instructions governing correct operation of the instrument must be observed. The operating company must make them available to the installation, maintenance, inspection and operating personnel.

Dangers arising from electrical components, energy discharged by the medium, escaping medium and incorrect installation of the device must be eliminated. See the information in the applicable national and international regulations.

1.5 Unauthorized Modification

Modifications of or other technical alterations to the instrument by the customer are not permitted. This also applies to replacement parts. Only the manufacturer is authorized to make any modifications or changes.

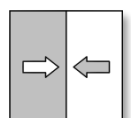

1.6 Inadmissible Modes of Operation

The operational safety of this instrument can only be guaranteed if it is used as intended. The instrument model must be suitable for the medium used in the system. The limit values given in the technical data may not be exceeded.

1.7 Safe working practices for maintenance and installation work

The safety instructions given in this operating manual, any nationally applicable regulations on accident prevention and any of the operating company's internal work, operating and safety guidelines must be observed.

The operating company is responsible for ensuring that all required maintenance, inspection and installation work is carried out by qualified specialized personnel.

1.8 Pictogram explanation



WARNING!

... indicates a potentially dangerous situation, non-observance of which could endanger persons, animals, the environment or objects.



INFORMATION!

... highlights important information efficient and smooth operation.



TIP!

... indicates recommendations that are not specifically necessary in certain situations but which could be useful.

2 Application purpose

The DS 11 is a combined display and switching device for differential pressure, over-pressure and under-pressure. This series is ideally suited for various measuring tasks in industrial applications or the sanitary field.

Typical applications are measuring differential pressure between the supply and return in heating systems and monitoring filters and pumps. Pressure chamber and measuring diaphragms are available in various materials. This allows the devices to be adapted to the various requirements.

3 Product and functional description

3.1 Function diagram

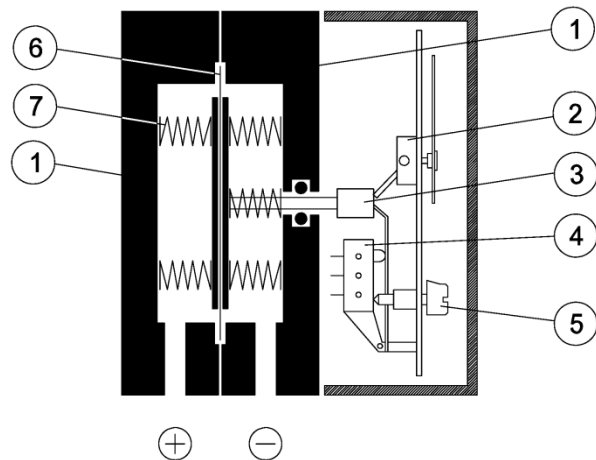

Item	Description
1	Pressure chamber
2	Motion train
3	Tappet
4	Micro-switch
5	Switch point setting
6	Measuring diaphragm
7	Measuring springs

3.2 Design and mode of operation

A robust and durable membrane measuring instrument is used as a measuring system, which is suitable for overpressure and underpressure measurements. The units use the same measuring principle for all three measuring applications.

In the rest position, the spring forces on both sides of the membrane are balanced out. Due to the pressure or underpressure to be measured, a single-sided force is created on the membrane which shifts the membrane system against the measurement range springs up to equalization of the spring forces. In case of overload, the membrane supports against the metallic support surfaces.

A centrally positioned tappet transfers the movement of the membrane system on the motion train and operating elements of the micro-switches.

4 Installation and assembly

The standard device is designed for wall mounting. The device can be mounted to even walls using the assembly foot that is cast to the middle of the device. It is also possible to fit the device in switch cabinets using the switch panel installation kit DZ11.

It is calibrated ex-works for vertical installation; this is the only allowed installation position.

To ensure safety during installation and maintenance, we recommend installing a suitable shut-off

valve on the system (see accessories section). This means that

- the device can be depressurized or taken out of operation
- the device can be disconnected from the power supply within the applicable system for repairs or inspections.
- a function test of the device can be performed on-site.

4.1 Process connection

- By authorized and qualified specialized personnel only.
- Only for the designated mechanical process connection (for the model, see the order code on the device type plate)
- The pipes need to be depressurized when the device is being connected.
- Appropriate steps must be taken to protect the device from pressure surges.
- Check the suitability of the device for the media to be measured.
- Maximum pressures must be observed.
- Check that the pressure connections do not leak before commissioning.

4.1.1 Pressure sensing lines

Remark



Commissioning and repeat tests can be carried out more efficiently by using a suitable shut-off device.

The pressure connections are marked with (+) and (-) symbols on the device. For differential pressure measurements, the higher pressure is connected to the (+) side and the lower pressure to the (-) side of the device. When measuring the pressure, only the (+) connection is used; the (-) connection is used to measure under-pressure.

The pressure sensing lines need to be kept as short as possible and installed without sharp bends to avoid interfering delay times.

The pressure sensing lines must be installed on a gradient so that no air pockets e.g. for liquid measurements or water pockets e.g. for gas measurements can be created. If the required inclination is not reached, water or air filters must be installed at suitable places.

If liquid measuring media are used the pressure connection lines must be deaerated, as liquid columns of different heights in the pipes can cause measuring errors. The instrument must be protected against frost if water is used as a medium.

4.1.2 Pressure surge absorption

Pulsating pressure on the system side can lead to wear and functional problems. To safeguard this, we recommend installing absorption elements in the pressure pipe line.

Fluid media

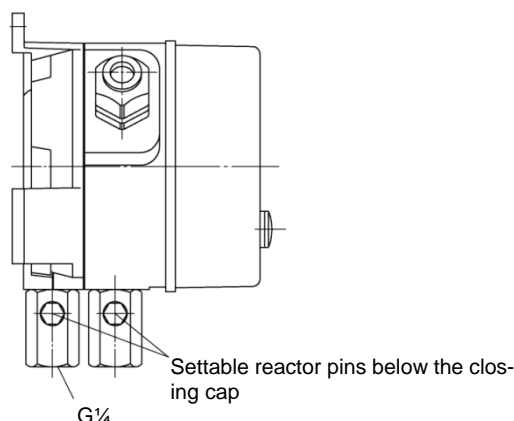

In the operational status, the reactor pins need to be set so that the measurement display follows the pressure changes with a delay.

Gaseous media

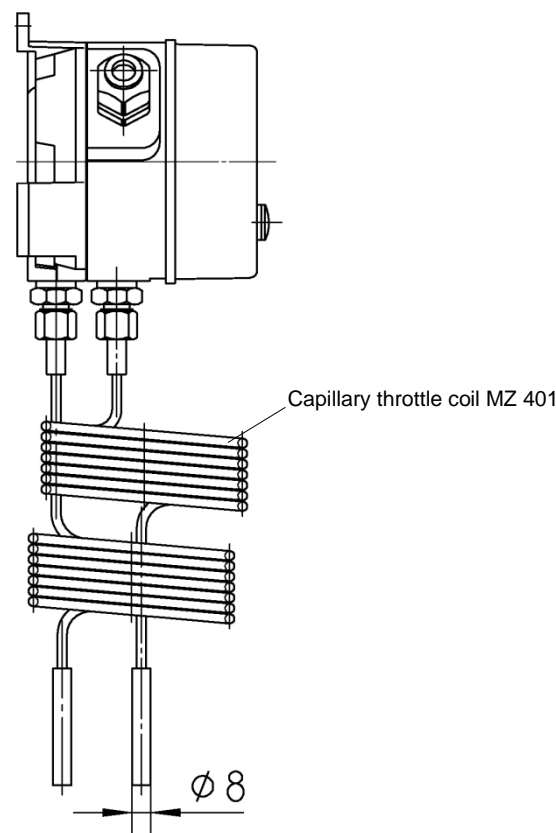

4.2 Electrical connections

- By authorized and qualified specialized personnel only.

- The electrical connection of the device shall be performed according to relevant VDE and local electricity board regulations.
- Disconnect the system from the mains before connecting the device.
- Add a fuse adapted to the energy requirements.

4.2.1 Cable socket and plug connection

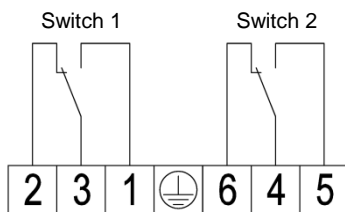
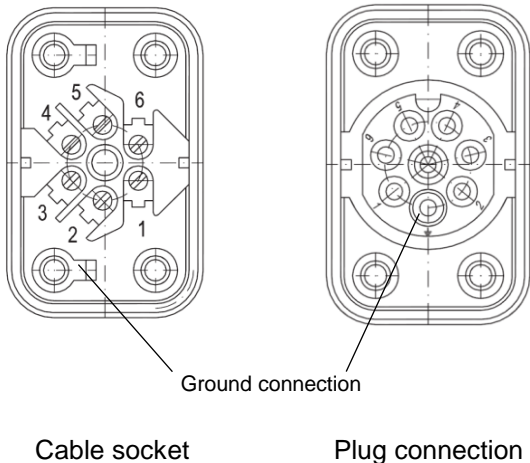

4.2.2 Numbered cables

For models with numbered cables, the cable numbers correspond with the presented terminal numbers.

5 Commissioning

All electrical supply, operating and measuring lines, and the pressure connections must have been correctly installed before commissioning. All supply lines are arranged so that there are no mechanical forces acting on the device.

Check that the pressure connections do not leak before commissioning.

5.1 Control Elements

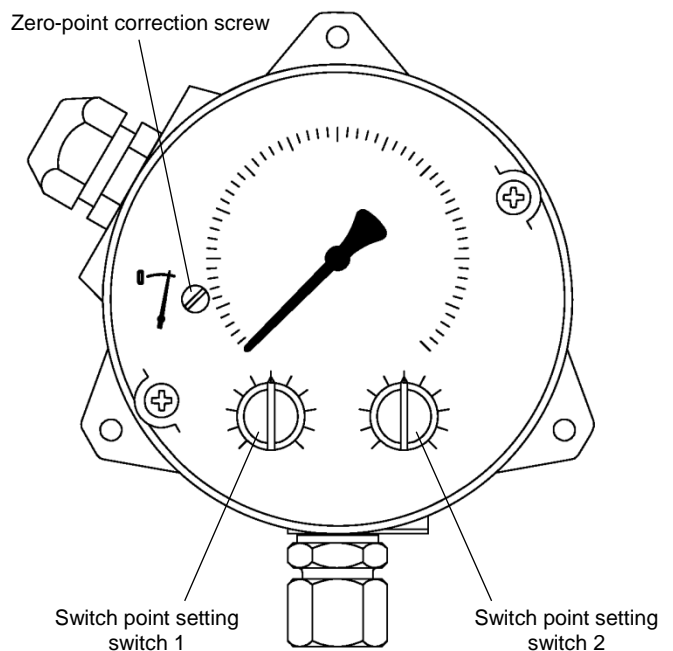

5.2 Zero point correction

- Depressurize the measuring chamber.
- Remove the hood
- Set the measurement value pointer to the zero-point scale using the zero point correction screw.
- Re-mount the hood.

5.3 Switch point setting

- Remove the plug in the hood.
- The required switch points can be set guide value scales according to the markings by using a screwdriver. The achievable setting accuracy is $\pm 5\%$.¹
- Replace the plug after completing the settings.

5.4 Function test

Remove both plugs in the hood for testing.

If the unit has two micro-switches, the stated test steps must be carried out for both switches.

After the test, the switch points need to be reset acc. to 5.3.

5.4.1 Checking the switch points when the system is depressurized.

No measurement is shown and the measurement display points to zero.

Turn the switch point setting button toward the zero-point until the micro-switch is activated.

¹More accurate settings can be made either in the factory or on site using suitable aids (test manometer, ohm meter etc.)

5.4.2 Testing when the system is operational

A measurement is shown. If despite operational pressure, no measurement is shown, you can generate a differential pressure by blocking the differential pressure lines on one side.

Turn the switch point setting button toward the measurement until the micro-switch is activated.

6 Maintenance and Repeat Tests

The instrument is maintenance-free.

To ensure reliable operation and a long service life, we recommend carrying out an annual test. The purpose of this test is to ensure that it functions correctly. There are instructions on how to carry out a function test in the commissioning section.

7 Transport

The measuring device must be protected against impacts. It should be transported in the original packaging or a suitable transport container.

8 Service

All defective or faulty devices should be sent directly to our repair department. Please coordinate all shipments with our sales department.

Warning



Process media residues in and on dismantled devices can be a hazard to people, animals and the environment. Take adequate preventive measures. If required, the devices must be cleaned thoroughly.

Return the device in the original packaging or a suitable transport container.

9 Accessories

- DZ11 Switch panel installation kit Ø 132
- DZ13/14 Blocking and equalization valve

10 Waste Disposal

Incorrect disposal may pose a risk to the environment.



use them.

Please help to protect the environment by always disposing of the work pieces and packaging materials in compliance with the valid national waste and recycling guidelines or reuse them.

11 Technical data

	General points
Admissible ambient temperature	-10 ... +70 °C
Admissible media temperature	-10 ... +70 °C
Admissible storage temperature	-15 ... +75 °C
Enclosure protection class	IP55 acc. to DIN EN 60529
Weight	1.2 kg (Pressure chamber in aluminium) 3.5 kg (Pressure chamber in stainless steel 1.4305)
	Measuring system
Measuring range ≤ 16 bar	Pressure spring measuring diaphragm system made of fabric-reinforced elastomers
Measuring range 0 ... 25 bar	Plate spring measuring system, plate spring made of DURATHERM®
Measuring range	0 ... 400 mbar to 0 ... 25 bar (see order code)
Rated pressure of the measuring system	25 bar
Max. static operating pressure	depending on measuring range (see order code)
Max. pressure load	on-sided over-pressure-proof up to the rated pressure of the measuring system resistance to under-pressure on the (+) and (-) side
Measurement accuracy	± 2.5% of the upper range value
Zero-point adjustment	Arranged in the front panel of the scale
	Switch contacts
Contact output	1 or 2 micro-switches with 1-pin changeover contact.
Switch point setting	can be set to reference scales from outside Smallest settable value approx. 5% of the end value of the measuring range.
Switch hysteresis	approx. 2.5% of the upper range value
Load data/contact	AC DC
U _{max}	250V 30V
I _{max}	5A 0.4A
P _{max}	250 VA 10 W
	Ports
Process connection	Inner thread G 1/4 Connecting shank G 3/4 DIN EN 837 Cutting ring connections for 6, 8, 10 mm (brass, steel galvanized or stainless steel)
electr. connection	Fixed wire numbered cables Cable connection socket 7-pole plug connection
	Materials
Pressure chamber	Aluminium GkAlSi10(Mg), painted black Aluminium GkAlSi10(Mg) with HART-COAT®-surface protection Chromium nickel steel 1.4305
Measuring diaphragm	Measuring diaphragm and seals made of NBR or Viton® Plate spring made of DURATHERM® NiCrCo alloy
Inner parts in contact with mediums	Stainless steel 1.4310, 1.4305
Hood	Makrolon
	Mounting
Installation position	vertical Wall mounting - three mounting feet Control panel assembly - control panel installation set DZ11 Ø132mm Pipe connection, pressure connections acc. to attached symbols - via screwed-in cutting or clamp screw connections - via screwed-in connection shanks acc. to DIN EN 837 for nipple connections acc. to DIN 16284
	Approvals
	type testing according to the regulations of Det Norske Veritas and the Germanischen Lloyd, test symbol DNV-GL EAC Declaration of conformity EN 61508 2001 Functional safety of safety-related electrical/electronic/programmable electronic systems requirements for SIL2

12 Dimensional drawings (all dimensions in mm unless otherwise specified)

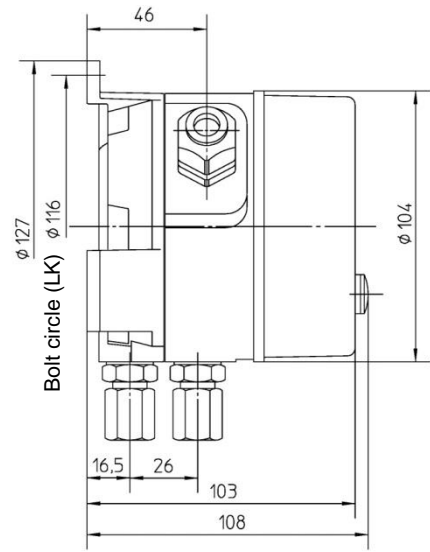
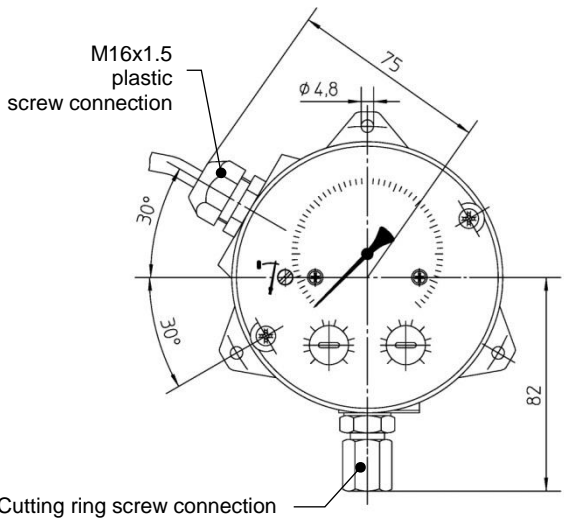

DS11 Wall mounting (Standard model)

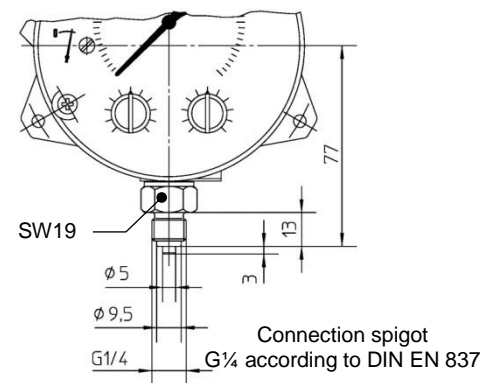
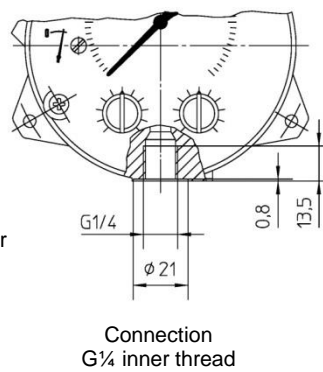
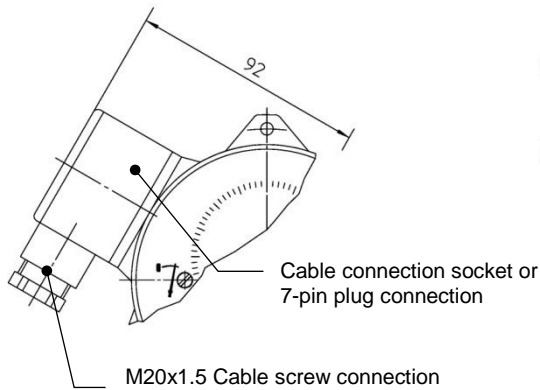

EL-connection variants

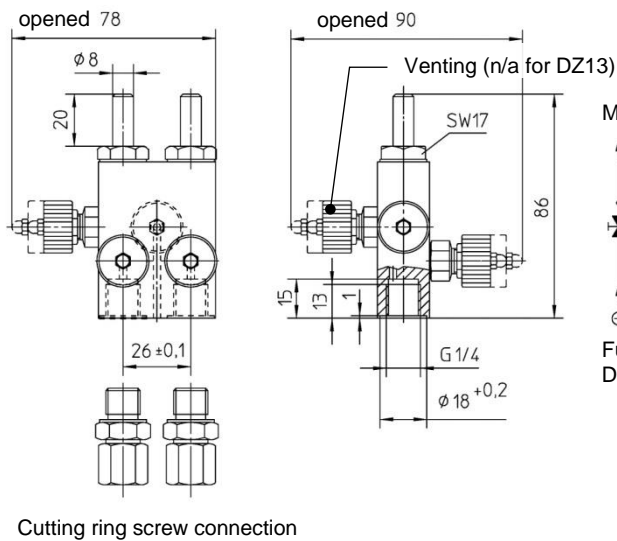

Process connection variants

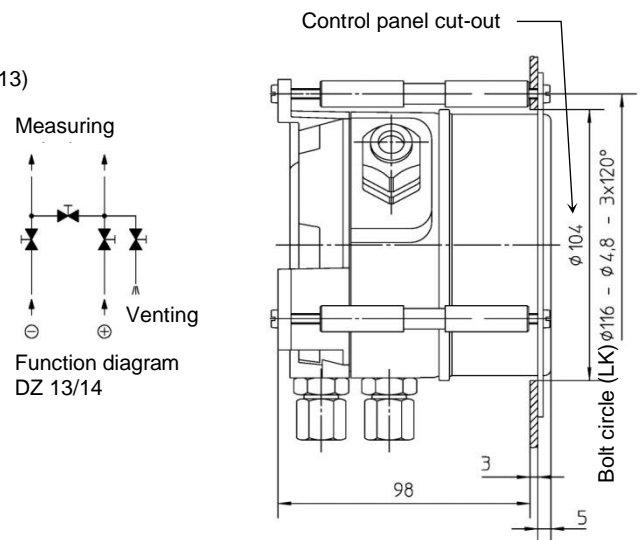

DZ 13/14 Four spindle equalization and shut-off valve

Mounting the control panel

13 Order Codes

Differential pressure measuring and switching device

Type DS11

												0	0
--	--	--	--	--	--	--	--	--	--	--	--	---	---

Measuring range	Max. stat. operating pressure												
0 ... 400... mbar	... 6 bar	>	8	3									
0 ... 0.6... bar	10 bar	>	0	1									
0 ... 1... bar	16 bar	>	0	2									
0 ... 1.6... bar	25 bar	>	0	3									
0 ... 2.5... bar	25 bar	>	0	4									
0 ... 4... bar	25 bar	>	0	5									
0 ... 6... bar	25 bar	>	0	6									
0 ... 10... bar	25 bar	>	0	7									
0 ... 16... bar	25 bar	>	0	8									
0 ... 25... bar	25 bar	>	0	9									
- 0.6 ... 0... bar	10 bar	>	3	0									
- 1 ... 0... bar	16 bar	>	3	1									
- 1 ... +0.6... bar	25 bar	>	3	2									
- 1 ... +1.5... bar	25 bar	>	3	3									
- 1 ... +3... bar	25 bar	>	3	4									
- 1 ... +5... bar	25 bar	>	3	5									
0 ... 30... psi	25 bar	>	H	5									
Measuring membrane / Seal													
NBR	NBR	>		N									
Viton®	Viton®	>		V									
DURATHERM®	NBR (Mb 0-25 bar)	>		D									
DURATHERM®	Viton® (Mb 0-25 bar)	>		E									
Pressure chamber													
Aluminium		>		A									
Aluminium HART COAT®		>		D									
Chromium nickel steel 1.4305		>		W									
Discharge port													
Inner thread G 1/4		>	0	1									
Inner thread 1/4 - 18 NPT		>	0	4									
Connection shanks with external thread G 1/4 B, brass		>	0	6									
Connection shanks with external thread G 1/4 B, Chrome-Nickel-Steel		>	1	1									
Connection shanks with external thread 1/4 - 18 NPT EXT Chrome-Nickel-Steel		>	1	4									
Cutting ring screw connection made of steel for 6 mm pipe		>	2	0									
Cutting ring screw connection made of steel for 8 mm pipe		>	2	1									
Cutting ring screw connection made of steel for 10 mm pipe		>	2	2									
Cutting ring screw connection made of 1.4571 for 6 mm pipe		>	2	4									
Cutting ring screw connection made of 1.4571 for 8 mm pipe		>	2	5									
Cutting ring screw connection made of 1.4571 for 10 mm pipe		>	2	6									
Cutting ring screw connection in brass for 6 mm pipe		>	2	8									
Cutting ring screw connection in brass for 8 mm pipe		>	2	9									
Cutting ring screw connection in brass for 10 mm pipe		>	3	0									
Switching Elements													
1 adjustable micro-switch		>		A									
2 adjustable micro-switches		>		B									
Electrical connection													
1 metre numbered cable, permanently wired		>		1									
2.5 metre numbered cable, permanently wired		>		2									
5 metre numbered cable, permanently wired		>		5									
Cable connection socket		>		K									
Plug connection (7-pin)		>		W									
DNV-GL-approved version with 3 m connection cable		>		Z									
SEV-approved version, 2 m connection cable VDE NYSLYO		>		U									
Casing protection class													
IP55		>		0									
IP65 (only with cable socket)		>		P									
Assembly options													
Panel mounting set		>		T									
Wall mounting		>		W									

13.1 Accessories

- DZ11 Control panel installation set Ø 132, comprising a front ring, distance columns and attachment screws.
- DZ13/14 The shutoff and equalization valves DZ13/14 in three and four spindle versions are highly suitable when mounting differential pressure devices. The following can be used for example:
- is a system is to be depressurized or taken out of operation
 - for repairs or tests to disconnect differential pressure devices within the affected systems from the mains supply

The shutoff devices can therefore also be used for function tests on site. In contrast to DZ13, the DZ14 also has a venting valve to vent the connected pipe system. The shutoff and venting valves are designed for the rated pressure level PN40. The housing can be selected in aluminium, brass or chrome-nickel-steel 1.4301. There are various pressure connections (see order code) available for process-side screw connections.

14 Manufacturer's Declarations and Certificates

14.1 EC Declaration of conformity



(Translation) **CE**

EU Declaration of Conformity

For the product described as follows

Product designation **Pressure Switch**
Type designation **DS11**

it is hereby declared that it corresponds with the basic requirements specified in the following designated directives:

2014/35/EU *Low Voltage Directive*
2011/65/EU *RoHS Directive*

The products were tested in compliance with the following standards.

Low Voltage Directive (LVD)

DIN EN 61010-1:2011-07 *Safety requirements for electrical equipment for measurement, control and laboratory use -*
EN 61010-1:2010 *Part 1: General requirements*

RoHS Directive (RoHS 2)

DIN EN 50581:2013-02 *Technical documentation for the assessment of electrical and electronic products with*
EN 50581:2012 *respect to the restriction of hazardous substances*

Also they were subjected to the conformity assessment procedure „**Internal production control**“.

Sole responsibility for the issue of this declaration of conformity in relation to fulfilment of the fundamental requirements and the production of the technical documents is with the manufacturer.

Manufacturer **FISCHER Mess- und Regeltechnik GmbH**
Bielefelder Str. 37a
32107 Bad Salzufflen, Germany
Tel. +49 (0)5222 974 0

Documentation representative Mr. Torsten Malischewski
B.Sc.
Development department

The devices bear the following marking:



Bad Salzufflen
29 Januar 2019

G. Gödde
Managing director



14.2 Certificate functional security SIL2



ZERTIFIKAT CERTIFICATE

Hiermit wird bescheinigt, das u.g. Produkt der Firma /
This is to certify, that the product described below from the company

Fischer Mess- und Regeltechnik
Bielefelder Straße 37a
32107 Bad Salzuflen
Deutschland

die Anforderungen der genannten Normen erfüllt.
fulfills the requirements of the following standard(s).

Geprüft nach **EN 61508:2010 Teile/Parts 1-7**
Tested in accordance with

Beschreibung des Produktes **Differenzdruck Mess- und Schaltgerät / Differential Pressure Switch**
(Details s. Anlage 1)
Description of product **Kontaktmanometer / Contact Pressure Gauge**
(Details see Annex 1)

Typbezeichnung **DS11, DS13 und DS21**
Type designation
MS11

Dieses Zertifikat bescheinigt das Ergebnis der Prüfung an dem vorgestellten Prüfgegenstand. Eine allgemein gültige Aussage über die Qualität der Produkte aus der laufenden Fertigung kann hieraus nicht abgeleitet werden.
This certificate is issued based on the examination of the product sample provided by the company mentioned above. A general statement regarding the quality of mass production products cannot be directly derived.

Registrier-Nr. / Registered No. 44 799 13759902
Prüfbericht Nr. / Test Report No. 3514 4398
Aktenzeichen / File reference 8000427935

Gültigkeit / Validity
von / from 2014-09-02
bis / until 2019-09-01

Zertifizierungsstelle der TÜV NORD CERT GmbH
Certification body of TÜV NORD CERT GmbH

Essen, 2014-09-02

TÜV NORD CERT GmbH Langemarckstraße 20 45141 Essen www.tuev-nord-cert.de machinery@tuev-nord.de

Bitte beachten Sie auch die umseitigen Hinweise
Please also pay attention to the information stated overleaf



ANLAGE ANNEX

Anlage 1, Seite 1 von 1
Annex 1, page 1 of 1

zum Zertifikat Registrier-Nr. / to Certificate Registration No. 44 799 1375902

Allgemeine Angaben
General information

Siehe Seite 1 des Zertifikates
See also page 1 of the Certificate

Produktbeschreibung:
Product description:

Differenzdruck Mess- und Schaltgerät / Differential Pressure Switch DS11, DS13, DS21
Kontaktmanometer / Contact Pressure Gauge MS11

Technische Daten:
Technical data:

Sicherheitsparameter / Safety Parameter
PFH = $2,29 \cdot 10^{-7}$ 1/h
HFT = 0
Typ-A-Teilkomponente / Type

Die Geräte können mit einer geeigneten Testung in SIL2 Anwendungen eingesetzt werden.
The components can be used with an appropriate testing in SIL2 applications



Zertifizierungsstelle der TÜV NORD CERT GmbH
Certification body of TÜV NORD CERT GmbH

Essen, 2014-09-02

TÜV NORD CERT GmbH

Langemarckstraße 20

45141 Essen

www.tuev-nord-cert.de

machinery@tuev-nord.de

14.3 GL approval



This is to certify:

That the Pressure Indicator

with type designation(s)
DS11, DS21

Issued to

FISCHER Mess- und Regeltechnik GmbH
Bad Salzuflen, Nordrhein-Westfalen, Germany

is found to comply with
DNV GL rules for classification – Ships, offshore units, and high speed and light craft

Application :

Product(s) approved by this certificate is/are accepted for installation on all vessels classed by DNV GL.

Location classes:

Temperature B
Humidity B
Vibration A*
EMC N/A
Enclosure B (IP54)

Issued at **Hamburg** on **2019-06-03**

This Certificate is valid until **2024-06-02**.

DNV GL local station: **Magdeburg**

Approval Engineer: **Holger Jansen**



Digitally Signed By: Rinkel, Marco

for **DNV GL**

Location: Hamburg, on behalf of

Joannis Papanuskas
Head of Section

This Certificate is subject to terms and conditions overleaf. Any significant change in design or construction may render this Certificate invalid. The validity date relates to the Type Approval Certificate and not to the approval of equipment/systems installed.



Form code: TA 251

Revision: 2016-12

www.dnvgl.com

Page 1 of 3

© DNV GL 2014. DNV GL and the Horizon Graphic are trademarks of DNV GL AS.

Job Id: **262.1-030917-1**
Certificate No: **TAA00002BW**

Product description

Pressure Indicator and Switching Device

Type: DS11, DS21
Pressure indicator: 270° scale, Indicator class: 2.5

Ranges	Max. Static Pressure DS11 [DS21]
0 - 400 mbar	6 [6] bar
0 - 0.6 bar	10 [10] bar
0 - 1 bar	16 [16] bar
0 - 1.6bar; 0 - 2.5bar; 0 - 4bar; 0 - 6bar	25 [16] bar
0 - 10 bar [only DS11]	25 bar

Max. medium temperature:	70° C
Gasket and membrane:	NBR or Viton
Wetted parts:	1.4310, 1.4305
Pressure gauge:	GKAlSi 10(MgCu), with hart coat or 1.4305
Output:	2 c/o - contacts separate adjustable
Rating:	3A, 250 V AC, 250 VA
Electrical connection:	fixed cable, length 3m, type MPRX 0,6/1 (Nexans) or equivalent

Type DS21: identical technical data, gaskets and membrane = viton

Application/Limitation

The Type Approval covers hardware listed under Product description. When the hardware is used in applications to be classed by DNV GL, documentation for the actual application is to be submitted for approval by the manufacturer of the application system in each case. Reference is made to DNV GL Rules for Ships Pt.4 Ch.9 Control and Monitoring Systems.

A* Vibration test: 2 to 17 Hz amplitude = 1.6 mm,
17 to 100 Hz acceleration = 2g

Type Approval documentation

Data sheets: DS11, Rev.B 2014-08
DS21, Rev.B 2014-08
Drawings: DS11 Dwg.-no. 24855, Rev.d; 2019-02-13
DS11 Dwg.-no. 02.011.00.24857.3, Rev.e; 2018-02-06
DS21 Dwg.-no. 26023, Rev.g; 2019-02-15
DS21 Dwg.-no. 02.021.00.26067.3, Rev.h; 2018-02-12
DS11-DS21 Dwg.-no. 02.021.01.34017.3, Rev.a; 2011-02-08
Test reports: TÜV 57 011 7, 1982-06-04
Type Approval Assessment Report 2019-05-21

Tests carried out

Applicable tests according to DNV GL Class Guideline CG0339, November 2016.

Marking of product

The products to be marked with:

- Model name
- Manufacturer name
- Serial number

Job Id: **262.1-030917-1**
Certificate No: **TAA00002BW**

Periodical assessment

The scope of the periodical assessment is to verify that the conditions stipulated for the type are complied with, and that no alterations are made to the product design or choice of systems, software versions, components and/or materials.

The main elements of the assessment are:

- Ensure that type approved documentation is available
- Inspection of factory samples, selected at random from the production line (where practicable)
- Review of production and inspection routines, including test records from product sample tests and control routines
- Ensuring that systems, software versions, components and/or materials used comply with type approved documents and/or referenced system, software, component and material specifications
- Review of possible changes in design of systems, software versions, components, materials and/or performance, and make sure that such changes do not affect the type approval given
- Ensuring traceability between manufacturer's product type marking and the type approval certificate

Periodical assessment is to be performed after 2 years and after 3.5 years. A renewal assessment will be performed at renewal of the certificate.

END OF CERTIFICATE

14.4 EAC Declaration of conformity



ЕВРАЗИЙСКИЙ ЭКОНОМИЧЕСКИЙ СОЮЗ ДЕКЛАРАЦИЯ О СООТВЕТСТВИИ

Заявитель Общество с ограниченной ответственностью «МАТИС-М». Место нахождения: 117261, город Москва, улица Вавилова, дом 70, корпус 3, комната правления, Российская Федерация. Адрес места осуществления деятельности: 109029, город Москва, город, Сибирский проезд, дом 2, корпус 12, Российская Федерация, Основной государственный регистрационный номер: 1037739575125, телефон: +7 495 725-23-09, адрес электронной почты: info@matis-m.ru

в лице Генерального директора Шарова Александра Анатольевича

заявляет, что Дифференциальный манометр с переключателем, тип DS21, DS11

Продукция изготовлена в соответствии с Директивой 2014/30/EU

Изготовитель "FISCHER Mess- und Regeltechnik GmbH"

Место нахождения: Bielefelder StraBe 37a, D-32107 Bad Salzufen, Германия. Филиал завода-изготовителя:

"FISCHER Mess- und Regeltechnik GmbH", Bielefelder StraBe 37a, D-32107 Bad Salzufen, Германия.

Код ТН ВЭД ЕАЭС 9026 20 400 0, серийный выпуск

Соответствует требованиям Технического регламента таможенного союза ТР ТС 020/2011 "Электромагнитная совместимость технических средств"

Декларация о соответствии принята на основании протокола № 01724-219-1-17/БМ от 31.01.2017 года.

Испытательной лаборатории Общества с ограниченной ответственностью «БизнесМаркет», аттестат

аккредитации регистрационный № РОСС RU.0001.21AB90 Схема декларирования: 3д

Дополнительная информация ГОСТ 30804.3.2-2013, ГОСТ 30804.3.3-2013. Условия хранения продукции в соответствии с ГОСТ 15150-69. Срок хранения (службы, годности) указан в прилагаемой к продукции товаросопроводительной и/или эксплуатационной документации.

Декларация о соответствии действительна с даты регистрации по 31.01.2022 включительно

(подпись)

М.П.

Шаров Александр Анатольевич

(Ф. И. О. заявителя)

Регистрационный номер декларации о соответствии: ЕАЭС № RU Д-ДЕ.АЛ16.В.65130

Дата регистрации декларации о соответствии: 01.02.2017

